

- > Port size: DN 8 ... 50, 1/4" ... 2" (ISO G/NPT)
- > High flow rate
- > Damped operation
- > Functional compact design
- > Solenoid interchangeable without tools (*Click-on*)
- > International approvals

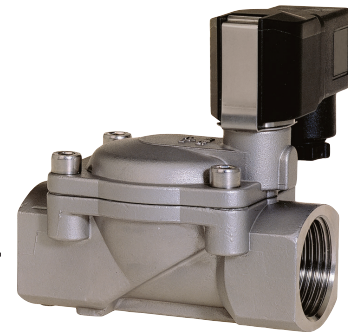

Click-on®
Stainless Steel



Technical features

Medium:
Slightly aggressive gases and liquid fluids

Switching function:
Normally closed

Operation:
Indirectly solenoid actuated

Mounting position:
Optional, preferably solenoid vertical on top

Flow direction:
Determined

Port size:
G1/4, G3/8, G1/2, G3/4, G1, G1 1/4, G1 1/2, G2
1/4 NPT, 3/8 NPT, 1/2 NPT, 3/4 NPT, 1 NPT, 1 1/4 NPT, 1 1/2 NPT, 2 NPT

Operating pressure:
See table

Differential pressure:
0,1 bar (1,45 psi) required

Fluid temperature:
-10° ... +90°C (+14° ... +194°F)

Ambient temperature:
-10° ... +50°C (+14° ... +122°F)

Material:
Body: Stainless steel (1.4408)
Seat seal: NBR
Internal parts: Stainless steel, PVDF

For contaminated fluids insertion of a strainer is recommended.

Technical data – standard models

Symbol	Port size	Orifice (mm)	Valve length (mm)	Flow kv value *1) (m³/h)	Operating pressure *2) (bar) (psi)	Weight (kg)	Model Solenoid in d.c./a.c.	
	G1/4	8	60	1,9	0,1 ... 16	1,45 ... 232	0,47	8273000.9101.xxxxx
	1/4 NPT	8	60	1,9	0,1 ... 16	1,45 ... 232	0,47	8274000.9101.xxxxx
	G3/8	10	60	3	0,1 ... 16	1,45 ... 232	0,45	8273100.9101.xxxxx
	3/8 NPT	10	60	3	0,1 ... 16	1,45 ... 232	0,45	8274100.9101.xxxxx
	G1/2	12	67	3,8	0,1 ... 16	1,45 ... 232	0,5	8273200.9101.xxxxx
	1/2 NPT	12	67	3,8	0,1 ... 16	1,45 ... 232	0,5	8274200.9101.xxxxx
	G3/4	20	80	6,1	0,1 ... 16	1,45 ... 232	0,65	8273300.9101.xxxxx
	3/4 NPT	20	80	6,1	0,1 ... 16	1,45 ... 232	0,65	8274300.9101.xxxxx
	G1	25	95	9,5	0,1 ... 16	1,45 ... 232	0,95	8273400.9101.xxxxx
	1 NPT	25	95	9,5	0,1 ... 16	1,45 ... 232	0,95	8274400.9101.xxxxx
	G1 1/4	32	132	23	0,1 ... 10	1,45 ... 145	2,6	8273500.9101.xxxxx
	1 1/4 NPT	32	132	23	0,1 ... 10	1,45 ... 145	2,6	8274500.9101.xxxxx
	G1 1/4	32	132	23	0,1 ... 16	1,45 ... 232	2,6	8273500.9151.xxxxx
	1 1/4 NPT	32	132	23	0,1 ... 16	1,45 ... 232	2,6	8274500.9151.xxxxx
	G1 1/2	40	132	25	0,1 ... 10	1,45 ... 145	2,84	8273600.9101.xxxxx
	1 1/2 NPT	40	132	25	0,1 ... 10	1,45 ... 145	2,84	8274600.9101.xxxxx
	G1 1/2	40	132	25	0,1 ... 16	1,45 ... 232	2,84	8273600.9151.xxxxx
	1 1/2 NPT	40	132	25	0,1 ... 16	1,45 ... 232	2,84	8274600.9151.xxxxx
	G2	50	160	41	0,1 ... 10	1,45 ... 145	3,85	8273700.9101.xxxxx
	2 NPT	50	160	41	0,1 ... 10	1,45 ... 145	3,85	8274700.9101.xxxxx
G2	50	160	41	0,1 ... 16	1,45 ... 232	3,85	8273700.9151.xxxxx	
2 NPT	50	160	41	0,1 ... 16	1,45 ... 232	3,85	8274700.9151.xxxxx	

xxxxx Please insert voltage and frequency codes
 *1) Cv-value (US) ≈ kv value x 1,2
 *2) For gases and liquid fluids up to 25 mm²/s (cSt)

Option selector

827*****.*****

Thread form	Substitute
ISO G	3
NPT	4
Port size	Substitute
1/4"	0
3/8"	1
1/2"	2
3/4"	3
1"	4
1 1/4"	5
1 1/2"	6
2"	7
Valve options	Substitute
Normally open (NO), from G1 1/4 with solenoid 9151 0,1 ... 16 bar (14,5 ... 232 psi)	01
Manual override	02
Seat seal FPM, Fluid temperature -5 ... +110°C (+23 ... +230°F)	03
Seat seal EPDM, for hot water, Fluid temperature +110°C 0,3 ... 16 bar (4,35 ... 232 psi) (up to G1) 0,3 ... 10 bar (4,35 ... 145 psi) (from G1 1/4)	14
Core tube stainless steel, Seat seal NBR, NO Fluid temperature +110°C (+230°F), for a.c. solenoid with rectifier	80
Version for drinking water with test according to KTW up to max. G1	88
Version for drinking water with test according to KTW/ NSF-approval Normally open (NO), up to G1 0,3 ... 16 bar (4,35 ... 232 psi)	89

Frequency	Substitute
See table frequency codes	xx
Voltage	Substitute
See Voltage codes	xxx
Solenoid options	Substitute
G1/4 ... 1 Operating pressure 0,1 ... 16 bar (14,5 ... 232 psi)	9101
G1 1/4 ... 2 Operating pressure 0,1 ... 10 bar (14,5 ... 145 psi)	9101
G1 1/4 ... 2 Operating pressure 0,1 ... 16 bar (14,5 ... 232 psi)	9151

Standard solenoid systems

Voltage and Frequency Solenoid 9101 *3) *4)					
Code Voltage	Code Frequency	Voltage	Frequency	Inrush	Holding
024	00	24 V d.c.	-	8 W	8 W
024	50	24 V a.c.	50 Hz	15 VA	12 VA
110	50	110 V a.c.	50 Hz	15 VA	12 VA
120	60	120 V a.c.	60 Hz	15 VA	12 VA
230	50	230 V a.c.	50 Hz	15 VA	12 VA
Voltage and Frequency Solenoid 9151 *3) *4)					
024	00	24 V d.c.	-	18 W	18 W
024	50	24 V a.c.	50 Hz	45 VA	35 VA
110	50	110 V a.c.	50 Hz	45 VA	35 VA
120	60	120 V a.c.	60 Hz	45 VA	35 VA
230	50	230 V a.c.	50 Hz	45 VA	35 VA

*3)  Us Coil only

*4) **Attention!** Standard core tube with copper shading coil.
Look for fluid resistant further options

Further versions on request!

Electrical details for all solenoid systems

Design	DIN VDE 0580
Voltage range	±10%
Duty cycle	100% ED
Protection class	EN 60529 IP65
Socket	Form A acc. to DIN EN 175301-803 (included)

According to DIN VDE 0580 at coil temperature of +20°C.
At operating state temperature the input power of a coil decreases by up to ca. 30% due to physical reasons.

Additional solenoid systems for hazardous areas

ATEX category	ATEX protection class	IP protection class	Solenoid	Standard voltages
II 2G II 2D	Ex eb mb IIC T4 Gb Ex mb tb IIIB T125°C Db	IP66	6106	24 V d.c., 110 V a.c., 230 V a.c.
II 2G II 2D	Ex eb mb IIC T4 Gb Ex mb tb IIIB T125°C Db	IP66	6126 *5)	24 V d.c., 110 V a.c., 230 V a.c.

Attention!

The conditions imposed on the Ex approvals lead to reduction of the permissible standard temperature ranges in the cases of explosion protected solenoids.

*5) from G1 1/4 / 1 1/4 NPT (16 bar)

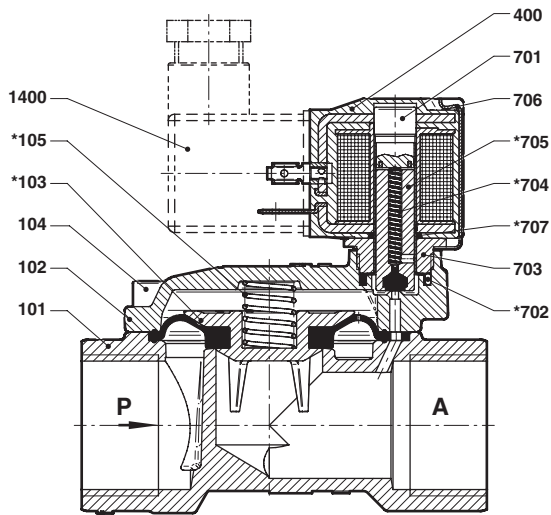
Section View
G1/4 ... 2
1/4 ... 2 NPT

No.	Description
101	Valve body
102	Valve cover
*103	Diaphragm
104	Allen head screw
*105	Pressure spring
400	Solenoid
701	Core tube
*702	O-ring
703	Screw piece
*704	Pressure spring
*705	Plunger
706	Spring clip
*707	O-ring
1400	Socket (included)

* These individual parts form a complete wearing unit.
 When ordering spare parts please state Model No. and Series No.

Dimensions

G1/4 ... 2
1/4 ... 2 NPT

Dimensions in mm
Projection/First angle

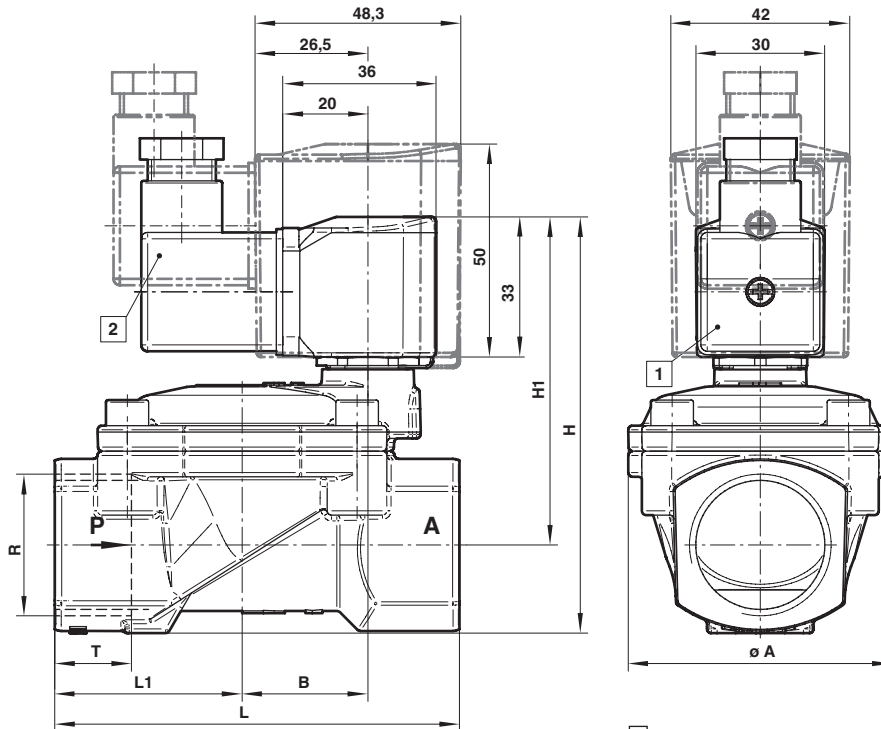

- 1 Solenoid rotatable 360°
- 2 Socket turnable 4 x 90°
(Socket included)

Port size R	A	B	H	H1	L	L1	T	Model
G1/4	44	19,5	78,5	67	60	27,5	12	8273000.9101.xxxxx
1/4 NPT	44	19,5	78,5	67	60	27,5	10	8274000.9101.xxxxx
G3/8	44	19,5	78,5	67	60	27,5	12	8273100.9101.xxxxx
3/8 NPT	44	19,5	78,5	67	60	27,5	10,5	8274100.9101.xxxxx
G1/2	44	19,5	81	67	67	31	14	8273200.9101.xxxxx
1/2 NPT	44	19,5	81	67	67	31	13,5	8274200.9101.xxxxx
G3/4	50	24	88	71,5	80	36,5	16	8273300.9101.xxxxx
3/4 NPT	50	24	88	71,5	80	36,5	14	8274300.9101.xxxxx
G1	62	29,5	97,5	77	95	44	18	8273400.9101.xxxxx
1 NPT	62	29,5	97,5	77	95	44	17	8274400.9101.xxxxx
G 1 1/4	92	44,5	124,5	95,5	132	60	20	8273500.9101.xxxxx
1 1/4 NPT	92	44,5	124,5	95,5	132	60	17	8274500.9101.xxxxx
G1 1/2	92	44,5	124,5	95,5	132	60	22	8273600.9101.xxxxx
1 1/2 NPT	92	44,5	124,5	95,5	132	60	17	8274600.9101.xxxxx
G2	109	54,5	142,5	108	160	74	24	8273700.9101.xxxxx
2 NPT	109	54,5	142,5	108	160	74	17,5	8274700.9101.xxxxx

Note to Pressure Equipment Directive (PED):

The valves of this series up to and including DN 25 (G1) are according to Art. 4 § 3 of the Pressure Equipment Directive (PED) 2014/68/EU. This means interpretation and production are in accordance to engineers practice wellknown in the member countries. The CE-sign at the valve does not refer to the PED. Thus the declaration of conformity is not longer applicable for this directive.

For valves > DN 25 (G1) Art. 4 § (1) Letter d) applies:

The basic requirements of the Enclosure I of the PED must be fulfilled. The CE-sign at the valve includes the PED. A certificate of conformity of this directive will be available on request.

Note to Electromagnetic Compatibility Guideline (EEC):

The valves shall be provided with an electrical circuit which ensures the limits of the harmonised standards EN 61000-6-3 and EN 61000-6-1 are observed, and hence the requirements of the Electromagnetic Compatibility Guideline (2014/30/EU) satisfied.

Note to EAC marking:

The EAC-marked products comply with the applicable requirements stated in the technical regulations of the Eurasian Economic Union.